

## Avant Craftsman Non-Locking Casement Fastener Kit

### Features & Benefits

- Classic design with a contemporary twist  
Create an elegant and stylish window
- Available in three finishes: Gold, Chrome and Satin
- Locking version available
- Matching casement stay available  
Perfectly matching hardware for every application
- Solid die cast zinc construction  
Heavyweight fastener with sturdy feel
- Supplied with colour coordinated screws  
Perfectly matching hardware - even down to the smallest details
- Dedicated non-locking fasteners  
Conforms to building regulations for non-locking windows

### Product Codes

AVAFNLGLD1

AVAFNLCHR1

AVAFNLSCR1



Gold



Chrome



Satin



## Avant Craftsman Non-Locking Casement Fastener Kit

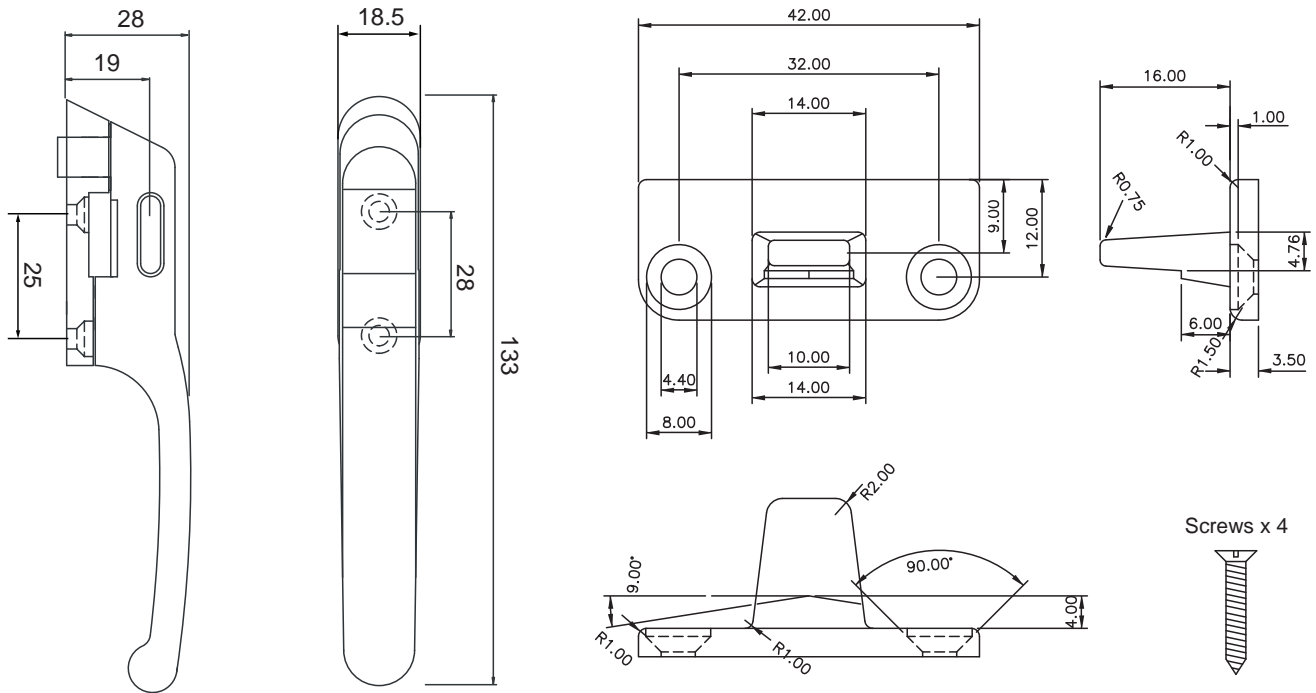

All dimensions are shown in millimetres

### Additional Benefits

- Dedicated non-locking fastener  
Conforms to building regulations for non-locking windows

### Product Codes

AVAFNLGLD1

AVAFNLCHR1

AVAFNLSCR1



Gold



Chrome



Satin

### Technical Specification

Designed for Timber windows

Certified to BS 7950: 1997

All finishes salt spray tested to 480 hours  
(BS EN 1670: Class 5)

Tested to 50,000 cycles

All products are subject to continuous development and improvement and we reserve the right to change specifications without prior notice.