

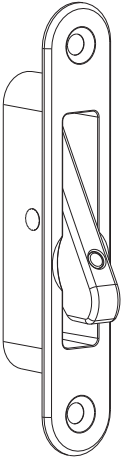

# Angel Face Fixed

## window opening control device instructions

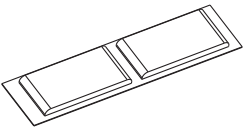

**Read guide from beginning to end before starting installation.  
Read all warnings and cautions during unit installation.**

<p><b>Parts Included</b> 2X Face Fixed Window Opening Control Devices</p> <p><b>Tools needed</b> Safety glasses Phillips head screw driver Drill / Driver 1/16" Drill bit Pencil Tape measure</p>		 <p>Buffer</p>  <p>Screws or bolts to suit</p>
---	--	--

### Warning

Window opening control device must be installed correctly and engaged to protect against accidental falls. Failure to do so may result in falls / injury. Window must be unlocked and opening control device disengaged to allow for emergency exit.

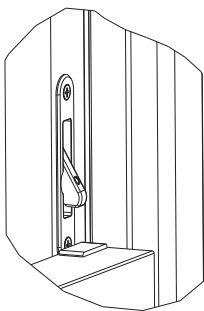

**To engage**  
Unit automatically engages when window is shut

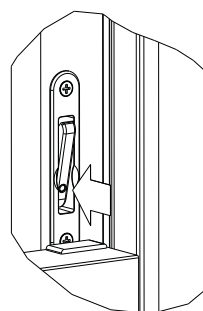

**Press dot to disengage**

### Warning

This package contains window opening control device parts for Double Hung windows. These devices must be installed following the enclosed instructions, and be engaged to help protect against accidental falls from windows.

Follow manufacturers' instructions for hand or power tools. Always wear safety glasses. Failure to do so may result in injury and / or product damage.

Use caution when working at elevated heights and around unit openings. Follow manufacturers' instructions for ladder and / or scaffolding. Failure to do so may result in injury or death.

This window opening control device was designed to protect against accidental falls by children 5 years old and younger. This window opening control device is not a substitute for supervision of young children. Tested to ASTM F2090 2008/2010



1

**MARK POSITION**

Close and lock bottom sash. Measure 4" (100mm) up from top of bottom sash and mark window frame. Opening control device may be fitted onto the sash stile or rebated.

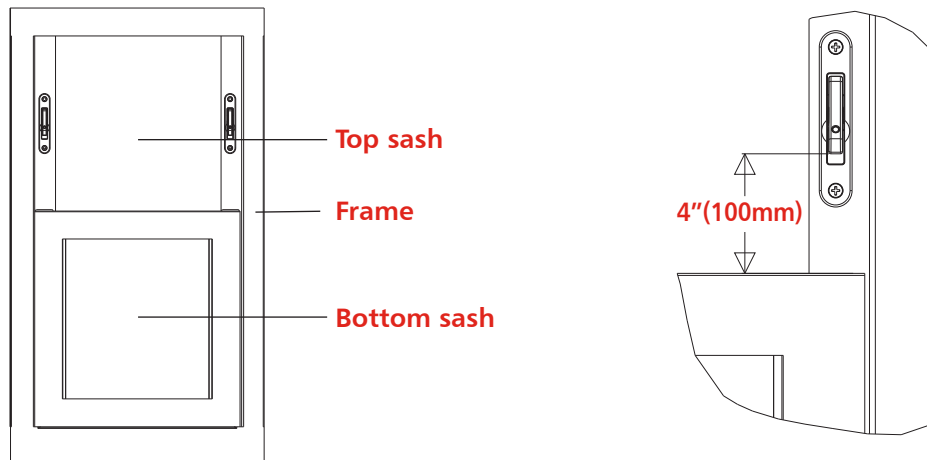

Position opening control device on sash as shown and align the bottom of the restrictor arm on the pencil mark.

2

**FIX RESTRICTOR**

Fixing limiter to sash frame.

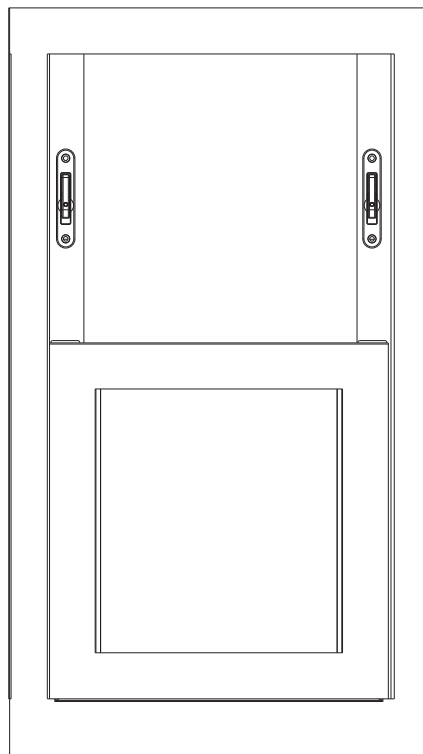
**Timber Frames**

Mark hole centers

Install Limiter using screws provided



## 3

## OPERATION

Disengage opening control devices on each side. Unlock and raise sash.

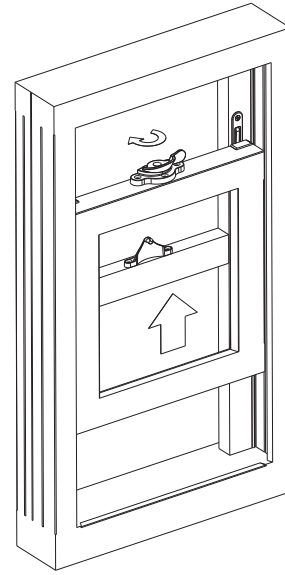
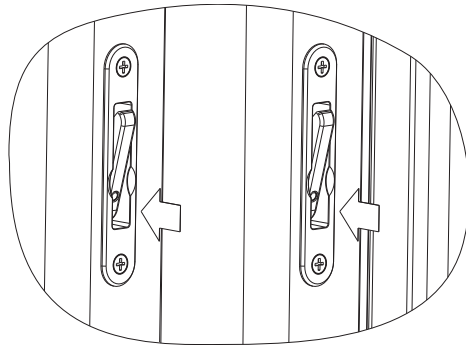

## 4

## FIT BUFFER

Fitting buffer. Remove buffer from backing. Position buffer directly under the opening control device, 1/16" from back edge. Lower the sash and apply firm pressure for five seconds to adhere buffer.

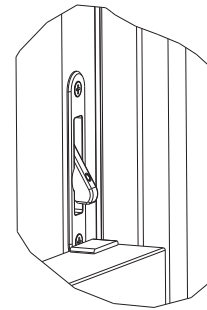
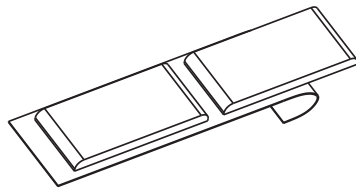

Strike plates (supplied separately) may be necessary to bridge the gap between Top and Bottom Meeting Rails.

## Warning

Buffers are small parts and could pose a choking hazard to young children.



## 5

## VERIFY INSTALLATION

Verify correct opening control device operation. Clear opening cannot exceed 4 inches.

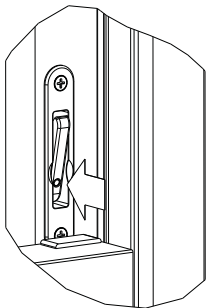

**1** Disengage opening control devices on each side

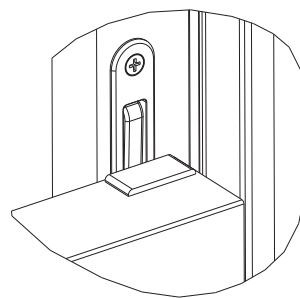

**2** Raise bottom sash

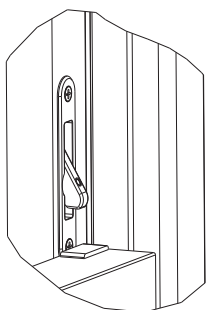

**3** Lower bottom sash  
Opening control device resets

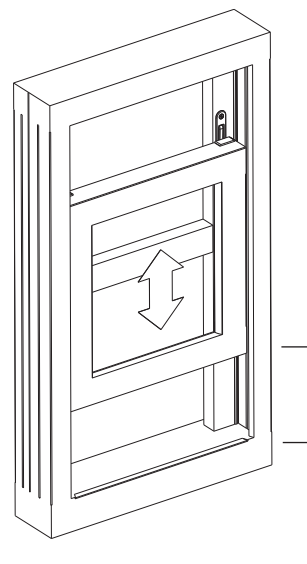

Clear opening cannot exceed 4 inches

Window opening control device application procedure is completed.

### Important

This package contains window opening control device parts for Double Hung windows. These devices must be installed following the enclosed instructions, and be engaged to help protect against accidental falls from windows. Failure to do so may result in fall/injury. This window opening control device is not a substitute for supervision of young children.

**Mighton Products Ltd, PO Box 1, Saffron Walden, Cambs CB10 1RG**

Tel: 0800 056 0471 Fax: 0800 581 703 Email: sales@mighton.co.uk

[www.angel-ventlock.com](http://www.angel-ventlock.com) [www.mightonproducts.com](http://www.mightonproducts.com)

**ANGEL VENTLOCK** Window safety for our children **Tested to ASTM F2090 2008/2010**

