



“ Breaking into sash windows is a doddle. Including those nice ones you make.”

Keep the burglar out. Fit Mighton Securibead™ & SBD Kit™

Secure every sash window you make.
Enhance your business reputation.



What is the easiest way to break into a sash window? Pop-out the parting beads using a chisel or screwdriver.

Worldwide, sash windows are the most frequently broken into.

The parting bead is the most vulnerable area. Followed by the meeting rail and bottom rail of the lower-sash.

Simply lock these items down now with the Mighton Securibead™ & SBD Kit™.

Using Mighton Securibead™ & SBD Kit™ prepares you for Secured by Design certification.

**IN OCTOBER 2008
MIGHTON SECURIBEAD™ &
SBD KIT™ WERE
SUCCESSFULLY TESTED TO
BS 7950**

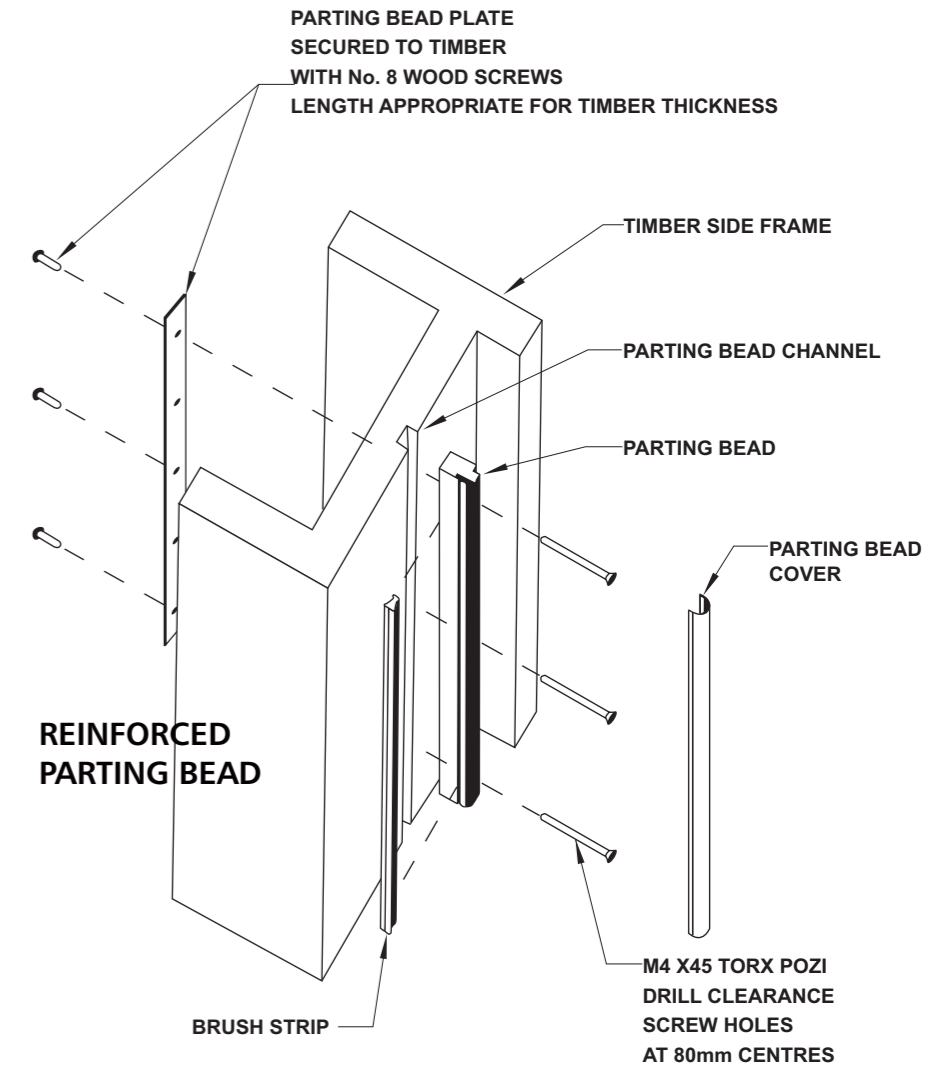

Bolts used to attach Securibead™ to the back plate are a security type that require a special tool.

The Mighton system can be used on weight balanced or spring balanced windows and consists of:

- Securibead™ & SBD Kit™**
- 2 Securifitch fasteners
- 4 Ventlocks
- 2 Cill locks
- Meeting rail guard
- Bottom rail guard

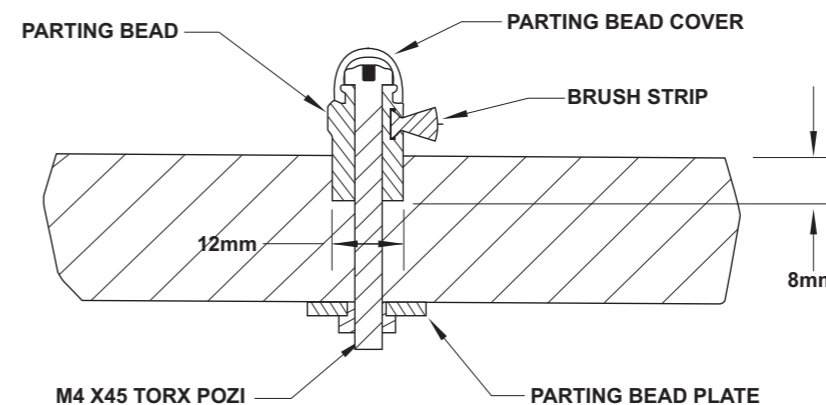

Secure it with Mighton Securibead™ & SBD Kit™ - BS7950



Give your next customer sash window security and peace of mind.

Securibead™ & SBD Kit™ brings a new dimension to sash window security.

1

Protect inside bottom rail



2

Protect inside meeting rail

3

Protect outside bottom rail



4

Protect outside meeting rail



SECURIBEAD™

Secure it with Mighton Securibead™ & SBD Kit™ - BS7950

SECURIBEAD™

SECURIBEAD™ & SBD KIT™

= BS7950

Enhanced security for windows



SECURIFITCH™
FASTENER



Captive keep



Cam engaged in the keep

Streamlined design with key



Each and every one of your customers will benefit from your expert advice on window security. And by using Mighton Securibead™ & SBD Kit™ you are giving yourself the opportunity of being accredited for Secured by Design certification. Mighton will guide you through the process of registration.

Armed with this quality security endorsement, you will be adding a powerful tool to your business.

Your sash window product will be superior giving you a substantial edge in your market place.

For more Securibead™ & SBD Kit™ information go to www.mightonproducts.com/securibead or Mighton Sales on 0800 056 0471.

Give every one of your customers extra security for their home or workplace.

SECURIBEAD™

www.mightonproducts.com/securibead

Secure it with Mighton Securibead™ & SBD Kit™ - BS7950

SECURIBEAD™

SECURIBEAD™

Sash window high level security

www.mightonproducts.com/securibead

Contact

Headquarters

Mighton Products Ltd
Hinxton Grange
Hinxton
Cambridge
CB10 1RG
United Kingdom

Phone 01223 497097

Fax 01223 839896

sales@mightonproducts.com

Securibead™ SBD Kit™
Securifitch™ Ventlock™ Cill lock™
are trademarks of Mighton Products
Patent Application No 0817137.3

